



Is our most advanced unit
for combined production of
shakes and sundaes



GK3



GK3

A shake & sundae heat-treatment combo freezer

The GK3 machine is our most advanced unit for combined production of shakes and sundaes.

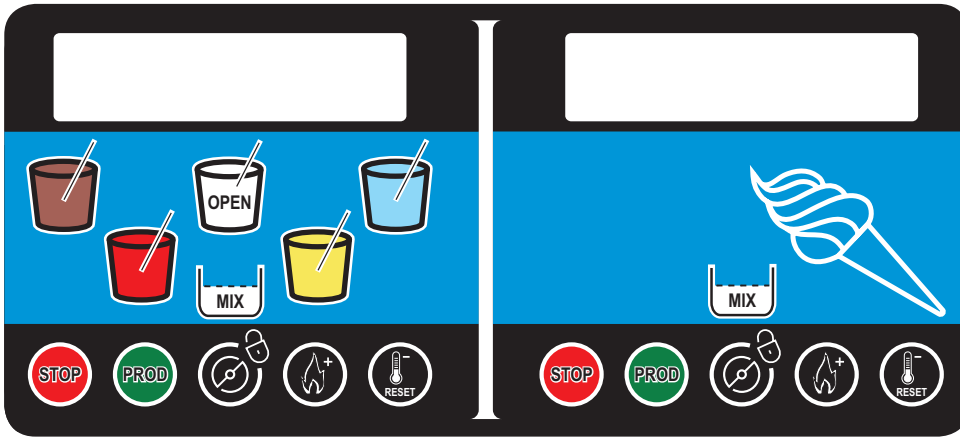

The GK3 has a very simple and easy-to-use control panel and the user-friendly display indicates what needs to be done in order to properly operate and maintain the machine.



Two Independent Freezers

It features two independent, high-volume freezers in one compact structure. If needed, one side can be stopped, while the other side remains in full operation.



Gear Pumps

Our patented and high performing mix gear pumps guarantee consistent overrun and constant yields, whilst the peristaltic pump syrup delivery system ensures good functionality with fluids or thick syrups that contain solid fruit particles.



Hard-O-Tronic

The Hard-O-Tronic consistency control system constantly monitors product viscosity, ensuring that both shake and sundae are always delivered in perfect serving conditions. Full food safety is ensured by the direct hot gas heat-treatment system, which eliminates all bacteria, while product temperature management helps reduce health hazards.

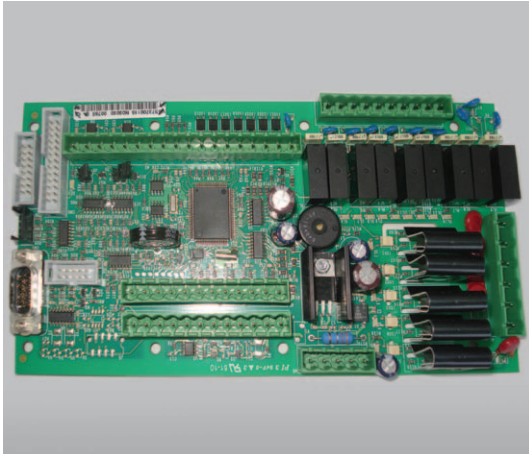

The Machine Memory

Performance data is stored in the machine memory and can be downloaded for valuable performance analysis, as well as for corrective actions.

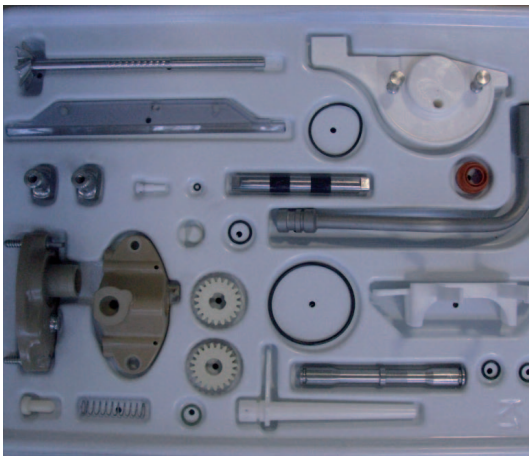

Cleaning: fewer parts

Only a few machine parts need to be disassembled and washed regularly, thus greatly simplifying the operation and keeping maintenance costs low. Thanks to the up to 30 days adjustable cleaning intervals of the machine, the running cost is cut by up to 50%.



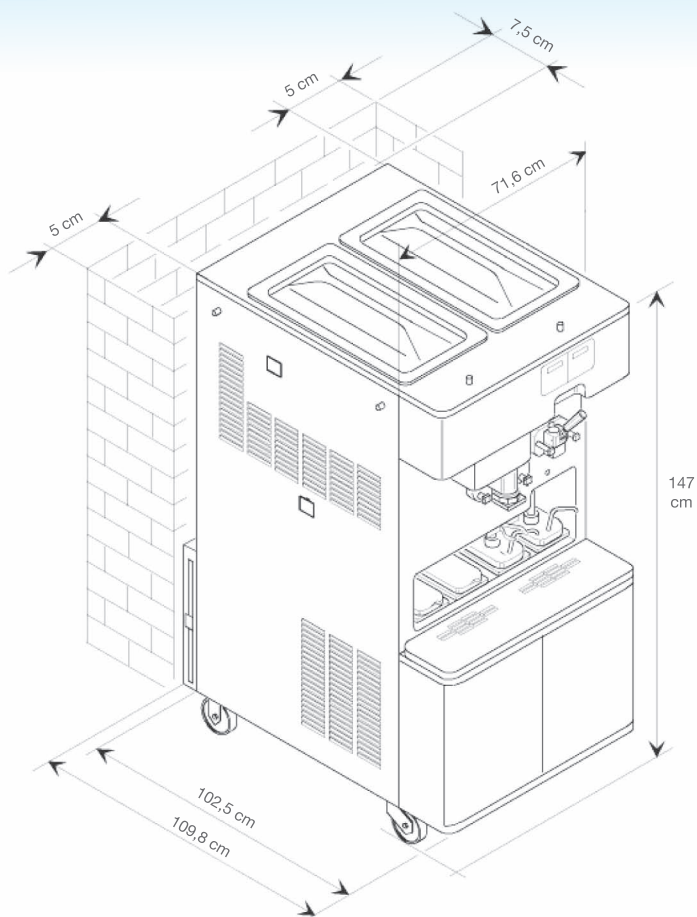

Main features

- Two independent freezers in one frame
- Reduced size, footprint & air space requirements
- Fully automatic heat-treatment & shake dispensing system
- Cleaning day count-down display
- Peristaltic pump syrup delivery system with external syrup valves
- Events download capabilities
- Consistent overrun & yields
- Mix level and temperature sensors

Optional

- Cone and cup dispenser



Carpi Care kit: request it from your dealer to always keep your machine hygienically perfect.

Technical Specifications of the GK3

Function	Shake & Sundae heat-treatment combo freezer	
	Shake side	Sundae side
Flavors	Five (5)	Single (1)
Hopper capacity	20 lt / 5,25 gal	20 lt / 5,25 gal
Cooling system**	Air	
Electrical supply***	400 V / 50 Hz / 3 ph	
Nominal Power	4,8 kW / 6,4 HP	
Dimensions (W x D x H)	710 mm (28 in) x 1040 mm (41 in) x 1500 mm (59 in)	
Net weight	395 kg / 871 lb	
Refrigerant****	R452	
Compressor	Shake side: 1.1 kW (1.5 HP)	Soft side: 1.1 kW (1.5 HP)
Beater motor	Shake side: 0.75 kW (1 HP)	Soft side: 1.1 kW (1.5 HP)

* Hourly production may vary with the mix used and the operating conditions. This data is collected at 25°C (77°F) ambient temperature.

** Water cooling system available upon request.

*** Alternative Voltage and Frequency solutions available upon request.

**** Alternative solutions available

GK3 is produced by Carpigiani with Quality System Certificate UNI EN ISO 9001.

All specifications mentioned must be considered approximate; Carpigiani reserves the right to modify, without notice, all parts deemed necessary.

Dealer



Via Emilia, 45 - 40011 Anzola dell'Emilia BOLOGNA, Italy Tel. +39 051 6505111 carpigiani.com

an Ali Group Company



The Spirit of Excellence